

JOHN B. LONG Co

Scoop Bucket Rock Duster

Model SBD-22 Scoop Bucket Duster

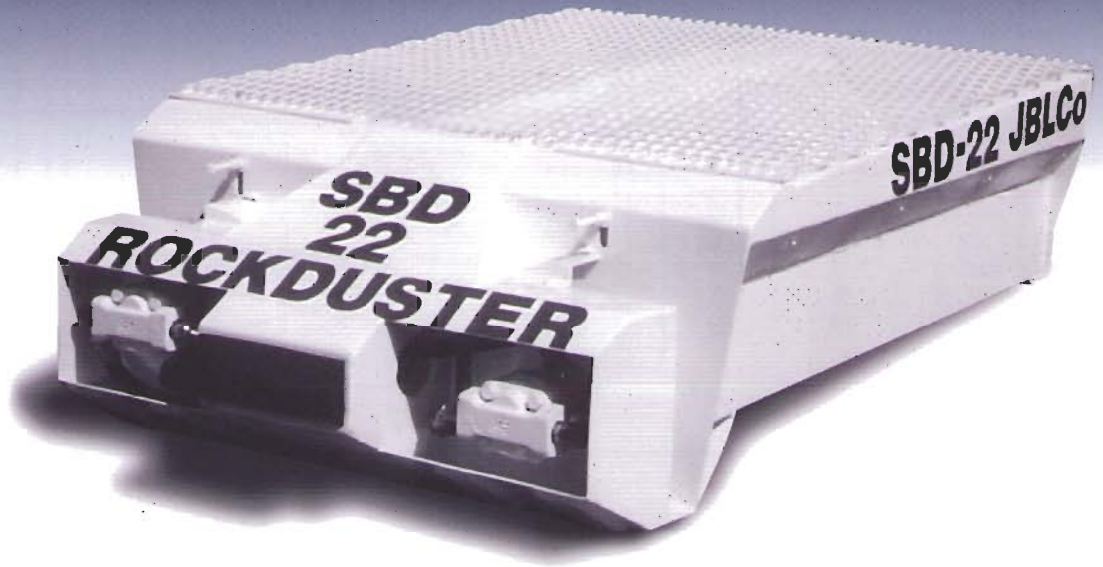

ONE MAN - ONE PASS - RIB TO RIB COVERAGE

John B. Long Co's **SBD-22 Scoop Rock Duster** has a unique design which allows it to fit into any standard scoop bucket. The two 5ft. hydraulic hoses quickly couples to the scoops hydraulic P.T.O. and allows the scoop operator to control the SBD-22 from the operator deck. The 1,500 pound hopper capacity is sufficient to dust all areas exposed during each shift. If additional dust capacity is required for freshening returns, bags may be stacked on either side of the SBD-22 inside the scoop bucket. The patented auger/slinger dust distribution system provides maximum performance and machine availability.

*MSHA Approved
Permissible Vehicles*

*JBLCo Provides
Profit Improvement/Cost Reduction*

John B. Long Co P.O. Box 50608 Knoxville, Tennessee 37950-0608 U.S.A.
Phone (423) 522-8686 Fax (423) 523-4996
Website: <http://www.jblco.com> Email: sales@jblco.com
Engineered and Manufactured in the U.S.A.

Rock Duster Model SBD-22 Scoop Bucket Duster Dimensions and Specifications

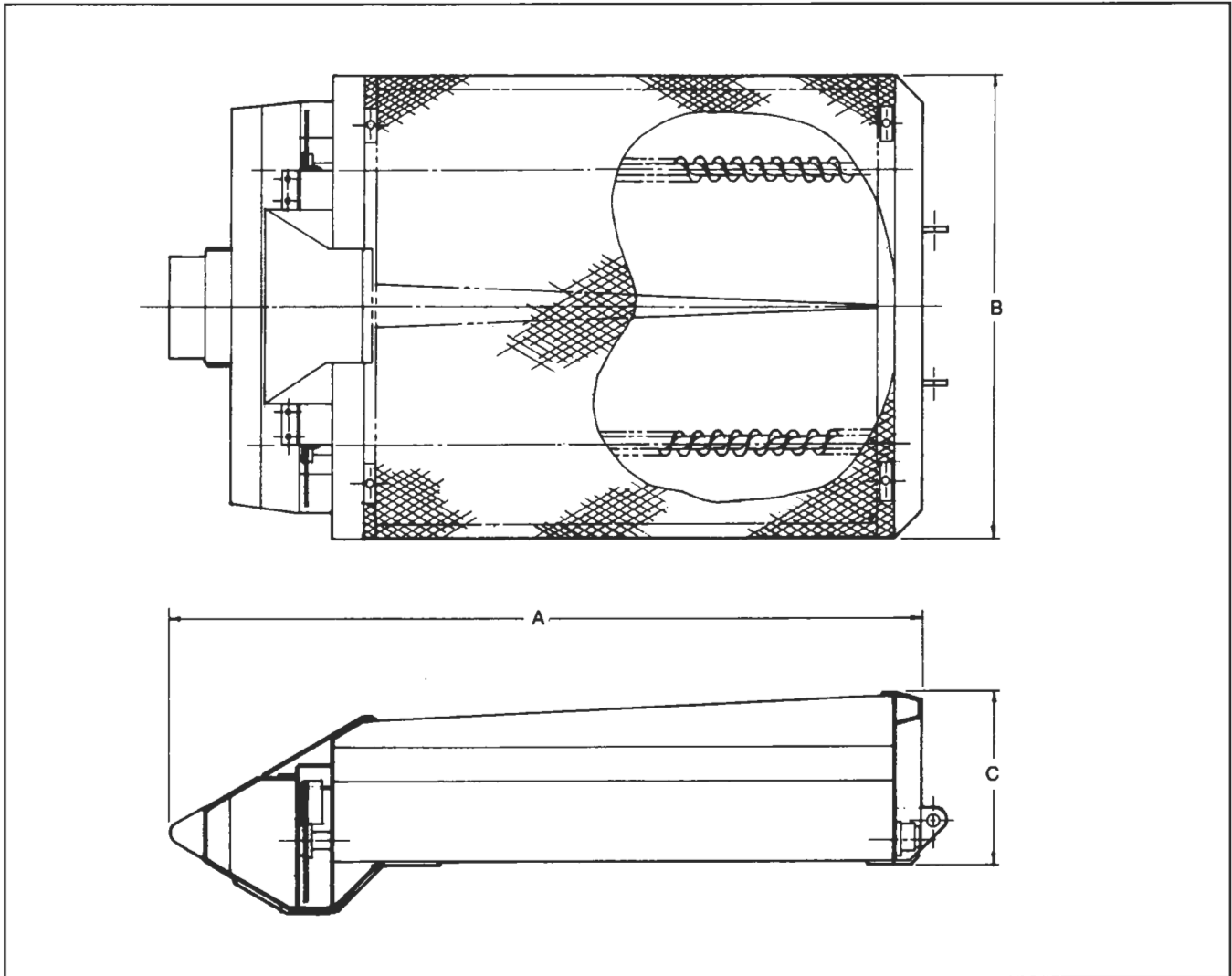

Mechanical:

A - Length = 7' 5"

B - Width = 4' 6"

C - Height = 1' 8"

Weight = 1,300 lbs.

Hopper Capacity = .75 tons

Discharge Rate = Adjustable

Hydraulic:

Hose Size: 3/4" male hose connection

P.T.O. Requirements: 15 G.P.M. @ 1500 P.S.I.

NOTE: Larger self-contained battery powered trailer type MD rock dusters available with dust capacities up to five tons. Contact your sales representative for details.